

TL-401 ドライバー錠 (インジケータ付き)

Screwdriver locks with indicator

新製品



▶特長 Characteristic

マイナスドライバーやコイン等で容易に開閉が可能なインジケータ付きの簡易ロックです。施錠・解錠がインジケータの「色」で確認できます。
This is the simplified lock with the indicator which makes it possible to open and close easily by minus drivers and coins. Able to confirm if it opens or closes by the color of the indicator.

▶用途 Application

防災機器・配電盤・分電盤・制御盤等
Disaster prevention devices / Distribution boards / Distribution panels / Control boards, etc.

▶仕様 Specification

回転規制カム組み換えによる左右回転兼用仕様です。ドライバー溝の回転はA・B間90°又はA・D間90°となります。止め金具は90°毎に固定位置を変えることができます。
推奨締付トルク: [取付ナット]3.0N・m (30.6kgf・cm)

[座金組込み十字穴付きなべ小ねじ]0.63N・m (6.4kgf・cm)

The specification for using both left and right rotation by changing the rotation control cam.

The rotation of chase of the driver is 90° between point A and B, or 90° between point A and D.

Able to change the fixed position of the fastener at every 90°.

Recommended tightening torque: [Fixing nut]3.0N・m (30.6kgf・cm)

[Pan Head Small Screw with Washer]0.63N・m (6.4kgf・cm)

▶材質と処理 Material & Finish

主材質: ZDC (亜鉛合金ダイカスト)・SPCC (冷間圧延鋼板)

主処理: Cr (クロムめっき)・3価クロメート

Material: ZDC (Zinc Alloy Die Casting)・SPCC (Cold-rolled Steel Sheet)

Finish: Cr (Chrome Plating)・Trivalent Chromate Treatment

⚠ 注意事項 Note

組み換え時の作業ミス防止のため、回転規制カム及び止め金具の組み換えはインジケータ表示が緑色の状態で行ってください。また、止め金具のダレ面の向きに注意してください。

Please operate to change the fastener and rotation control cam when it is indicated green for preventing the operational errors.

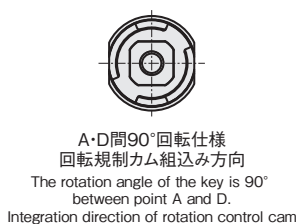
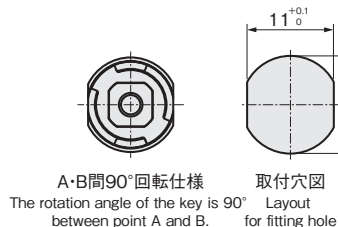
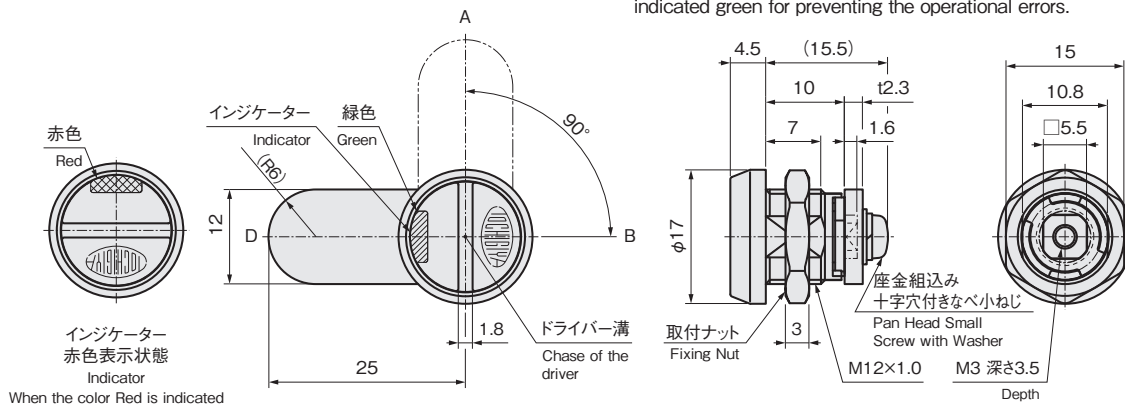
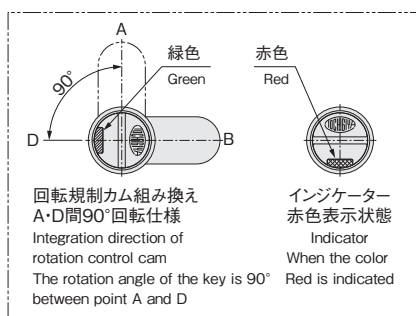

▶仕様 Specification

型番 Model No.	自重 (g) Net Weight (g)
TL-401	18.1